

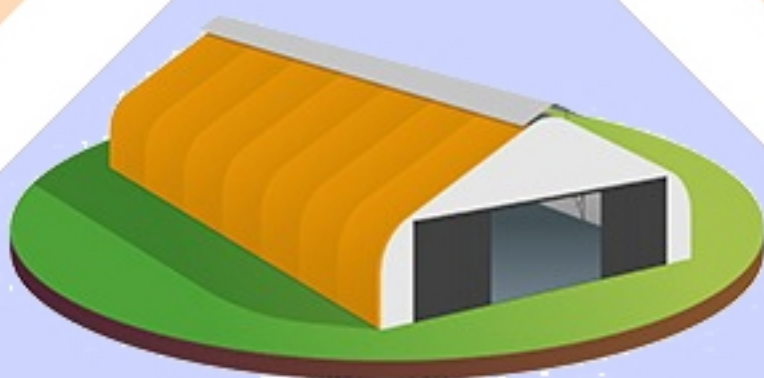

# Jumbo Bags

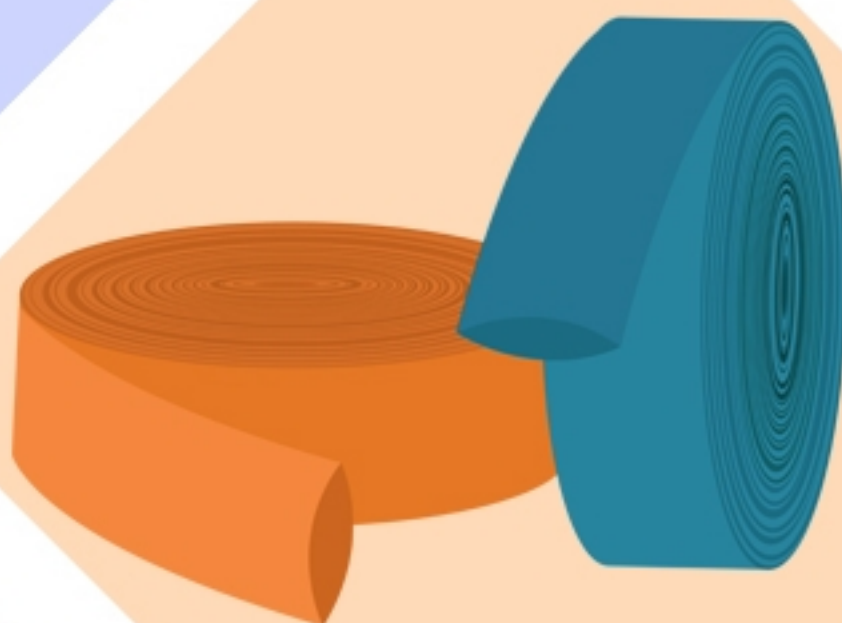

[www.chamundi.org.in](http://www.chamundi.org.in)



# About us



Chamundi Extrusions Private Limited (CEPL) an ISO 9001:2015 and BIS certified company, was established in the year 2010 with the objective of manufacturing high quality tarpaulin-based waterproofing products and Agriculture Products like HDPE Tarpaulin, Pond Lining, Grow Bags, Vermi Bed, Jumbo Bags, Cement Bag, Sand Bag, Woven Fabric, Wagon Cover, HDPE Delivery, Lapeta Pipe etc. With over a decade in the business, CEPL is a leading brand in the country. CEPL is a pioneer and a leading manufacturer of tarpaulins in the country. This is a result of the vision and perseverance of its founder director Mr. Barbarik S Ghuwalewala.

We produce all our products from premium quality raw-material procured from the most renowned vendors in the market. They are then processed under the guidance of expert professionals with the help of most modern machineries. The quality is tested under vital parameters at several stages of production. We make sure that our products comply with the international quality standards, global market competition and value for money.

The spirit of our company is inspired by a set of enduring values and beliefs: Integrity, Passion, Quality, Respect and Responsibility. We are guided by passion and hard work of our Company's Directors who possess strong business acumen and hold rich industry experience. This is coupled with the efforts of our diligent team of professionals who have always played a vital role in our company's growth over the years.

Based on our values and beliefs, our Brands Chamundi Tarp, Pinnacle, Splash Tarpaulin, Janta Tripal is a mark of Quality and Reliability under which our Products and Services are offered to our esteemed clients and customers.

With an installed capacity of 600 MT per month, we have integrated plant, fully equipped with latest models of extruder machines besides cutting, stitching, weaving, stretching, printing and lamination machines of brands like LOHIA, GM, Polyseal etc respectively.

Besides, we also have an advanced R&D as well as quality control lab and to ensure quality of the product, we conduct rigorous tests on parameters like weight, tensile strength, UV protection and gauge etc. The advanced machines and well-trained workforce enable us to execute all the bulk orders with perfection and within stipulated time frame.





# Jumbo Bags



FIBC Bags, also known as Jumbo Bags/ Bulk Bags, are one of the most cost effective types of packing for storage and transportation of a wide range of materials such as chemicals, food, metal etc. Manufactured from tubular/ flat woven fabric, these bags have a large storage capacity. These bags are custom designed as per the client's requirement, thus offering a wide range of bags to choose from. We offer bags for both single-trip (5:1) and multi-trip (6:1 or 8:1) purposes. The SWL Range of the bags start from 250 kg up to 2000 kg.

All our FIBC bags are manufactured in accordance with ISO 21898 and certificates held after testing at reputed labs across the globe.

FIBC is available with four loops for easy forklift handling, having spouts at top & bottom for easy fill & discharge, in standard constructions of U-panel, 4-panel, circular/ tubular and form stable/ baffle bags. FIBC may be coated or uncoated, with or without liner, printed, UN certified, standard White or any other colours as per requirements.

We at Chamundi Extrusions Pvt. Ltd. are committed to our customer to deliver high quality custom made FIBC along with all the required assistance including after sales support to assist our customer in all the ways to meet the end user satisfaction.



## Types of FIBC/Jumbo Bags

- ☑ **U-Panel Bag:** A U-Panel bag requires 2 seams along 2 opposite sides to create 2 panels and a "U" Panel shape. These bags generally have corner lifting loops but can also come in cross-corner loops.
- ☑ **Four Panel Bag:** A 4-Panel bag has 4 separate panels sewn together to form a "4" Panel shape. These bags generally have corner lifting loops but can also come in cross-corner loops.
- ☑ **Circular Bag:** A Circular / Tubular body design is seamless ideal bag for fine materials with cross-corner lifting loops.
- ☑ **Single or One Loop Bag:** A Single or one loop bags is a tubular body bag with just one single point lifting loops which is reinforced or wrapped by a sleeve. These bags are bulk product handling bags which can come with or without liners and are very cost effective bags.



# Jumbo Bags



☑ **Double or Two Loop Bag:** A double or two loop bags is a tubular body bag with two lifting loops which is reinforced or wrapped by sleeves.

## Lifting Loops

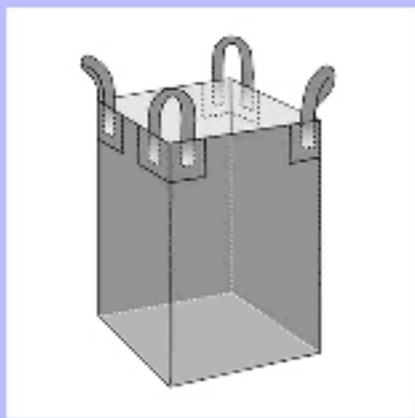

Cross-Corner Loops

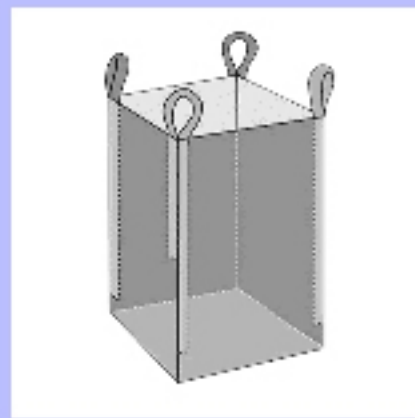

Side-Seam Loops

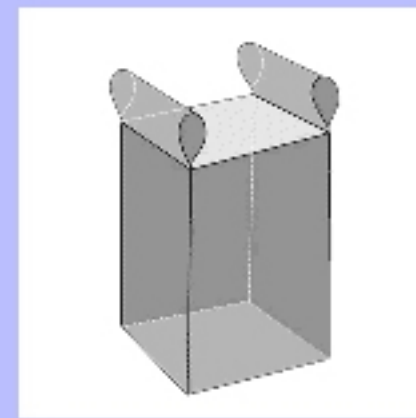

Sleeve Lift

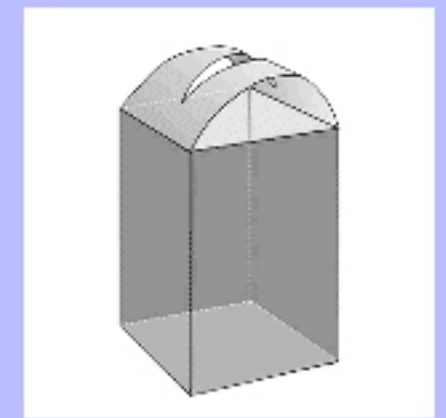

Hood Lift

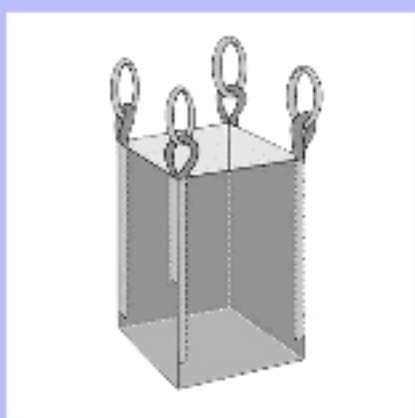

Ancillary Loops

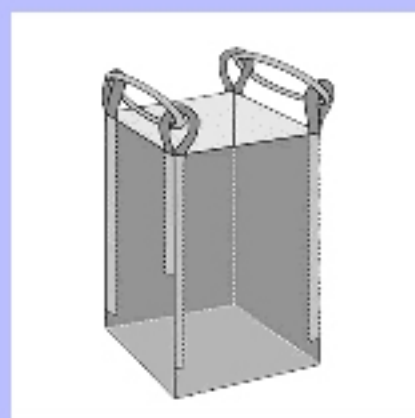

Double Stevedore Straps

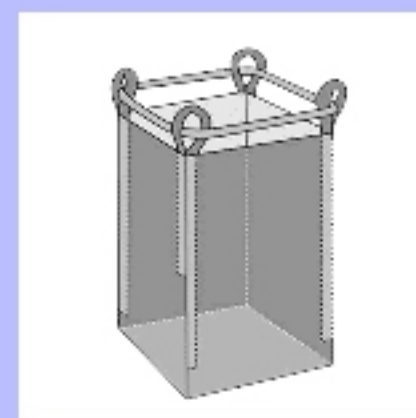

Single Stevedore Strap

## Filling & Closure

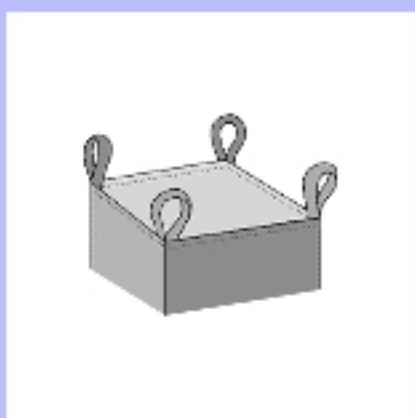

Open Top with Hem

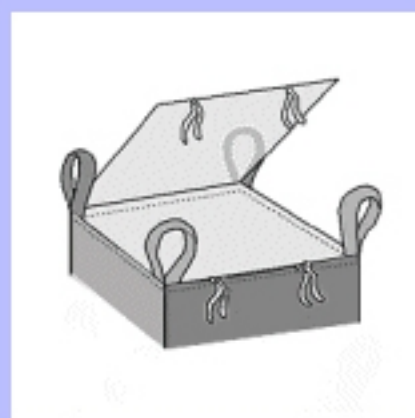

Tie-Down Flap

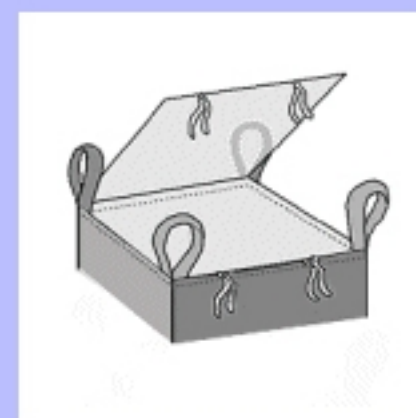

Duffel Top

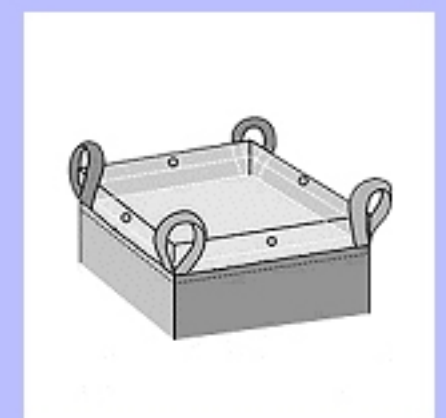

Open Top & Tightening Holes

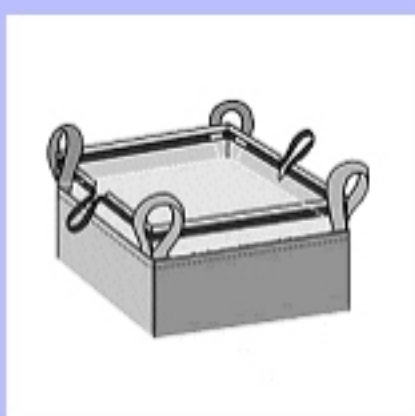

Open Top with Draw Cord

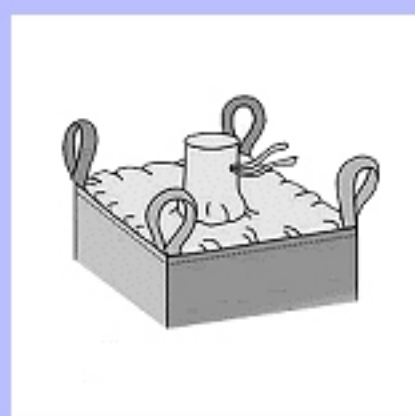

Filling Spout

# Jumbo Bags



## Discharge

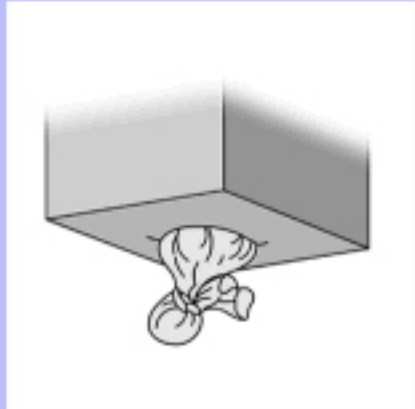

Discharge Spout

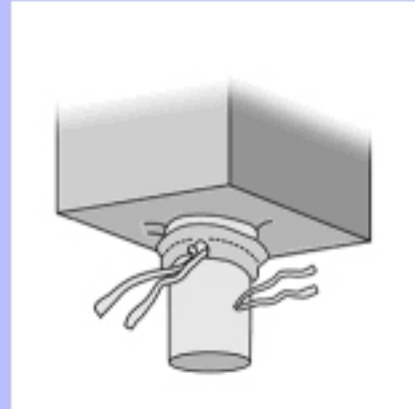

Discharge Spout with Iris Protection

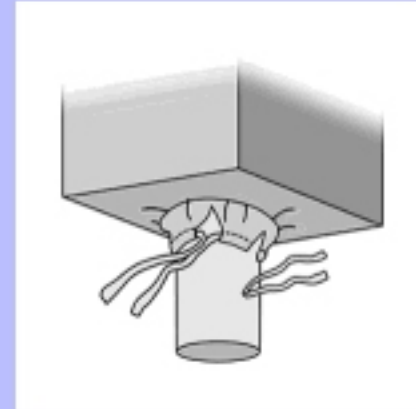

Discharge Spout with Petal Closure



Discharge Spout with Sewn Cover

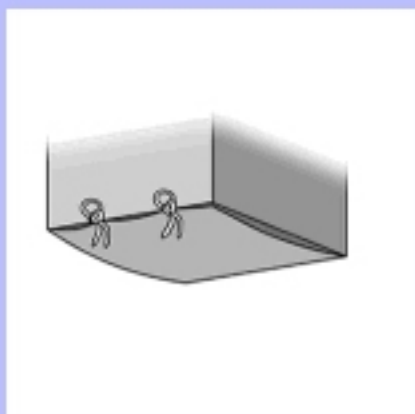

Discharge Spout with Protection Flap

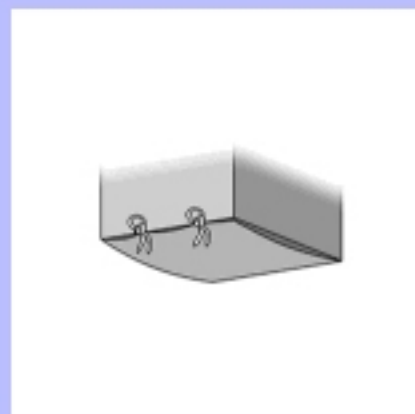

Full Drop Bottom

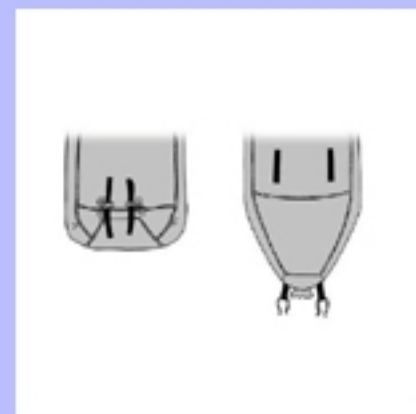

Quick Discharge / Conical base



# Infrastructure



The manufacturing facility of Chamundi Extrusions Private Limited is located in Howrah, West Bengal, India. Chamundi Extrusions Private Limited has been certified with ISO 9001:2015 and is spread on a land area of more than 60,000 square feet with a constructed facility of more than 40,000 square feet. Our manufacturing capacity has significantly increased over the years with the adoption of world class technology which has helped us strengthen our product portfolio not only in India but across the globe. We Export to USA, Europe, Middle East, Africa, Fiji.

The facilities include manufacturing unit, design unit and a warehouse. Our manufacturing unit spreads across the sprawling area and is supported by our design unit which enables us to manufacture our range of products conforming to internationally accepted Standard. Our well-equipped warehouse facilitated with the latest technology ensures safe stocking of products and aids in meeting the supply of voluminous consignments of our clients across the country. Committed to lead the industry with our comprehensive range, we rely on cutting edge technology to offer cost effective solutions to our clients.

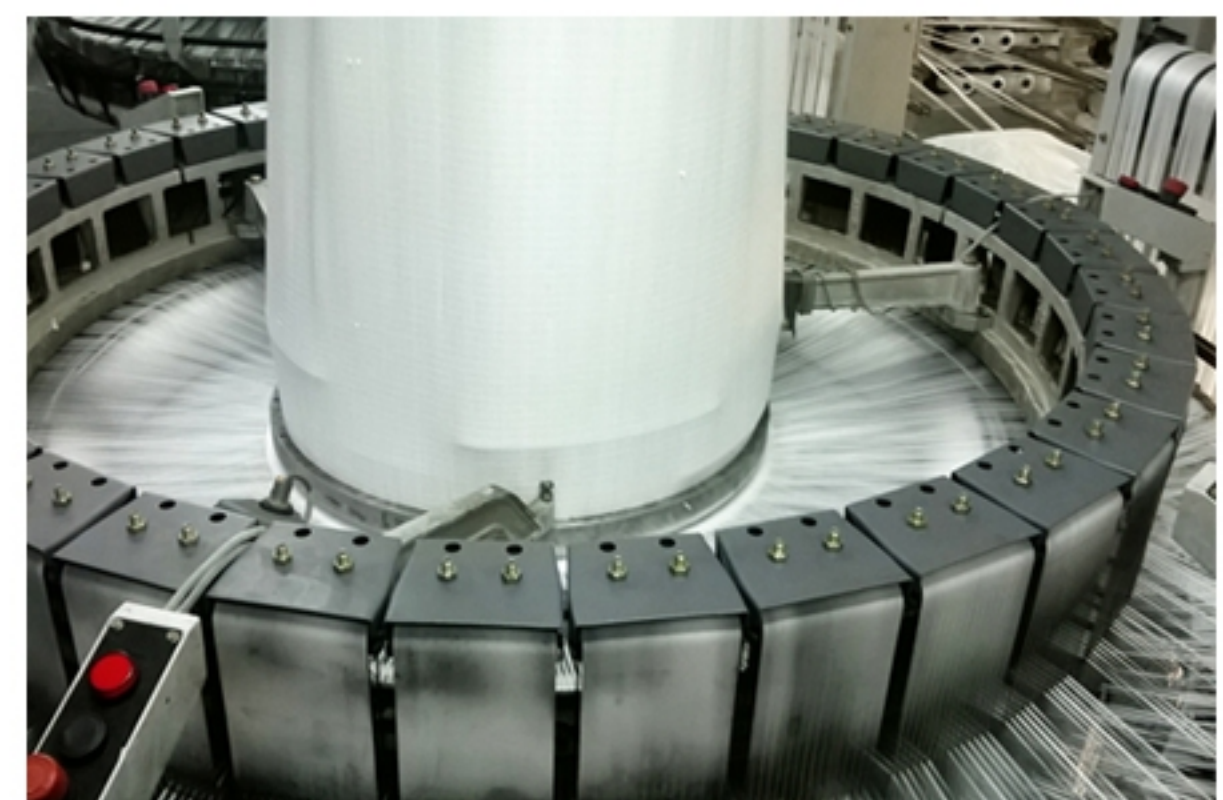





Registered Office  
**CHAMUNDI EXTRUSIONS PVT LTD**  
HOUSE OF TARPAULINS & PLASTIC ENGINEERING

Ranihati, Amta Road, Near Gabberia Hospital  
P.S. : Panchla, P.O. : Jala Biswanathpur,  
Vill. : Vyer Chak, Howrah – 711322

P: +91 76050 77701

E: [marketing@chamundi.org.in](mailto:marketing@chamundi.org.in)

W: [www.chamundi.org.in](http://www.chamundi.org.in)